

Gas Bubble Generation in Water

Using Dolomite's Small Droplet System

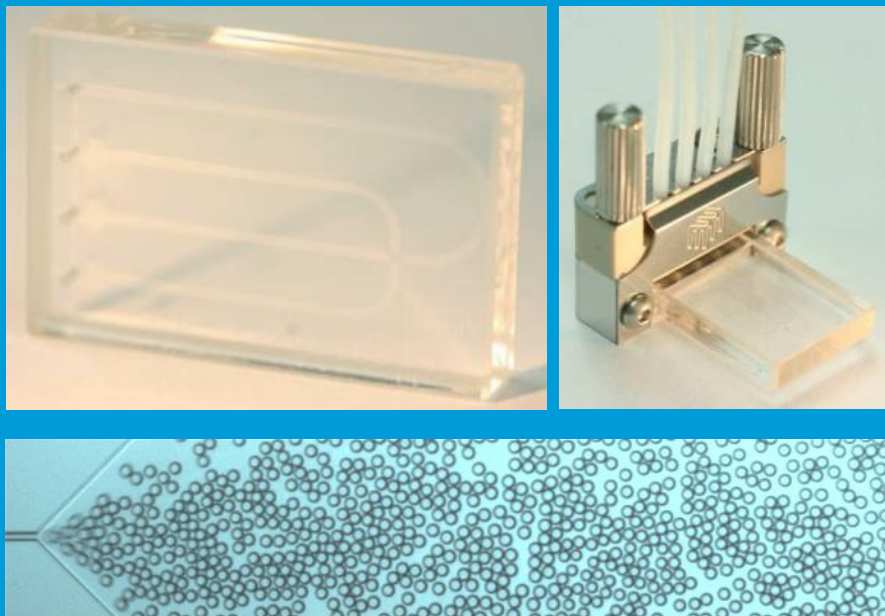

Application Note	Page
Summary	2
Bubble and Foam Technology	3
System Configuration	4
Test Results	7
Conclusion	10
IP License	10
Appendix A: System Component List	11
Appendix B: Alternative Chip Options	11

Summary

This application note describes the use of Dolomite's hydrodynamic flow-focussing based Small Droplet System for formation of gas bubbles in liquid. Applications range from R&D, to medical diagnostics, to material science and petrochemicals.

Compared with traditional methods, the relative ease and reliability of generating monodisperse gas bubbles makes this system suitable for cutting edge technological applications. The wetted parts have chemical stability and offer optical access for visual diagnostics.

The Small Droplet System setup is described in detail to illustrate the assembly of components along with the fluidic setup. The system is used in a test case to generate nitrogen bubbles in water. 1% SDS is used as a stabilizing agent and dissolves in the carrier water phase.

By controlling the pressure on the pumps, stable and monodisperse bubbles are found to be produced over a wide range of sizes. The surfactant is found to sufficiently stabilize the bubbles on-chip. The P-Pumps are operated over the pressures from 0 to 6 bar. Further, the gas utilized to create bubbles is easily changed by connecting the desired gas bottle to the P-Pump.

In the test case, the smallest bubbles achieved were 6 μm stable monodisperse. The largest stable monodisperse bubbles were found to be 15 μm . Larger bubbles were also observed, but these suffer from slight loss of monodispersity at approximately 18 μm . Still larger bubbles were produced of approximately 40 μm and found to be unstable polydisperse interspersed with coalescence. Bubbles generation frequency – 10-1000 Hz.

Bubble & Foam Technology

Microfluidic systems offer convenient methods for highly controlled formation of gas-liquid and liquid-liquid emulsions. Closely related are foams, formed by trapping pockets of gas in a liquid or solid. In most foams, the volume of gas is large, with thin films of liquid or solid separating the regions of gas.

Microbubbles have a growing number of uses in R&D, engineering, medical diagnostics as contrast agents for imaging, food industry as texture tailoring, or fat reduction, fuel cell driven energy industry, detergents and cleaning products as delivery agents for key active ingredients, petroleum and natural gas recovery, material science as to synthesis of meso-porous materials and in clinical applications such as targeted drug delivery.

Traditional methods for bubble generation rely on a nozzle emitting gas into quiescent fluid. Conventional methods of foam production result in polydisperse media, where gas present in large amounts is divided into gas bubbles of many different sizes. Additionally, their production has been difficult owing to requirements for a widespread, low cost and energy efficient production method. The reliable production of small-sized bubbles is recognized as a process of major difficulty. During foam production, the carrier fluid in the liquid state can rearrange while the bubble (once formed) stays relatively unchanged.

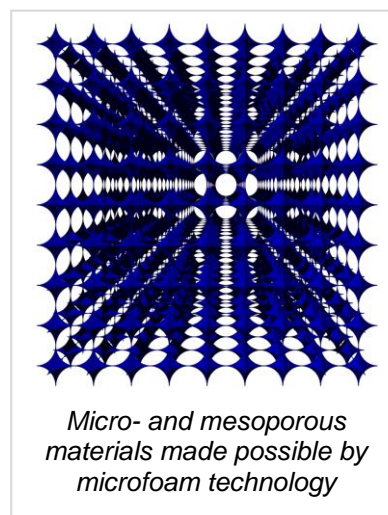

The flow focussing method described here builds upon this by adding reliability, and extends the range of sizes producible by the effects of the moving carrier fluid. Using the Small Droplet System microfluidic setup with a Small Quartz Droplet Chip, reliable monodisperse bubble generation is accomplished. Dolomite's advanced fabrication processes enable precision manufacturing of the chip with feature size as low as 8 μm . Glass chips are equally as suitable as Quartz chips for bubble generation applications (see **Appendix B** for a list of alternative chips that Dolomite offer that will work with the Small Droplet System for bubble generation).

This chip based system is shown to be capable of producing bubbles as small as 6 μm diameter. Flows rates are controlled via Dolomite P-Pumps providing pulseless flow, which is a convenient and reliable method for controlling bubble size.

When used with the Small Droplet System, the Small Quartz Droplet Chip is shown to have the ability to tune the volume fraction of the gaseous phase from zero to one. The rate of flow of the fluids through the microfluidic device determines the mechanism of formation of the bubbles – from break-up controlled by the rate of flow of the liquid (at low capillary numbers, and in the presence of strong confinement by the walls of the microchannels), to dynamics dominated by inertial effects (at high Weber numbers). The system used here is capable of producing bubbles from a few to tens of micrometers in diameter with a narrow size distribution.

System Configuration

As mentioned previously, the Small Droplet System used in this application note is based around the Small Quartz Droplet Chip (5 μ m etch depth) (Part No. 3200152). This is a microfluidic device designed for generating small droplets in the size range 2 - 30 μ m. It has a hydrophilic coating and a near-circular microchannel profile at the junction for stable bubble generation. The Small Quartz Droplet Chip (Hydrophilic) is used with a Linear Connector 4-way (Part No. 3000024) and a Top Interface 4-way (Part No. 3000109) to interface the fluidic connection between the tubing and chip.

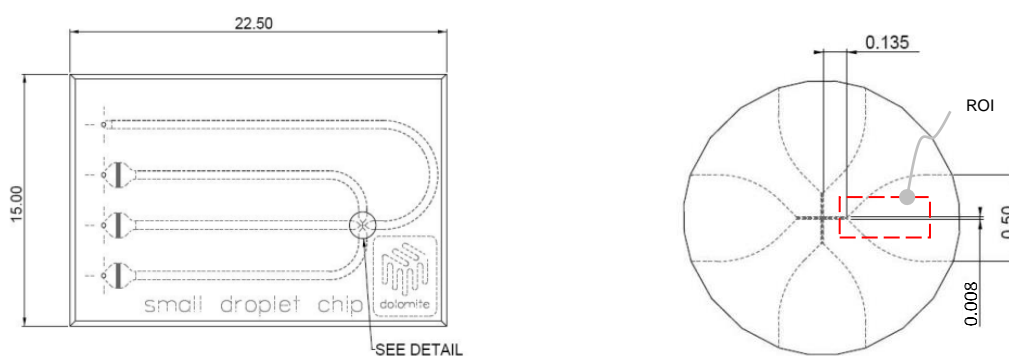

Left: Sketch of Small Quartz Droplet Chip (Part No. 3200152). Right: Detailed view of the junction with dimensions. The region of interest (ROI) is bounded by the red box and is the focus of imaging.

Two MitoS P-Pumps (Part No. 3200016) deliver nitrogen and water to the chip. Nitrogen is used as the droplet phase; 1% SDS solution in water is used as the carrier phase.

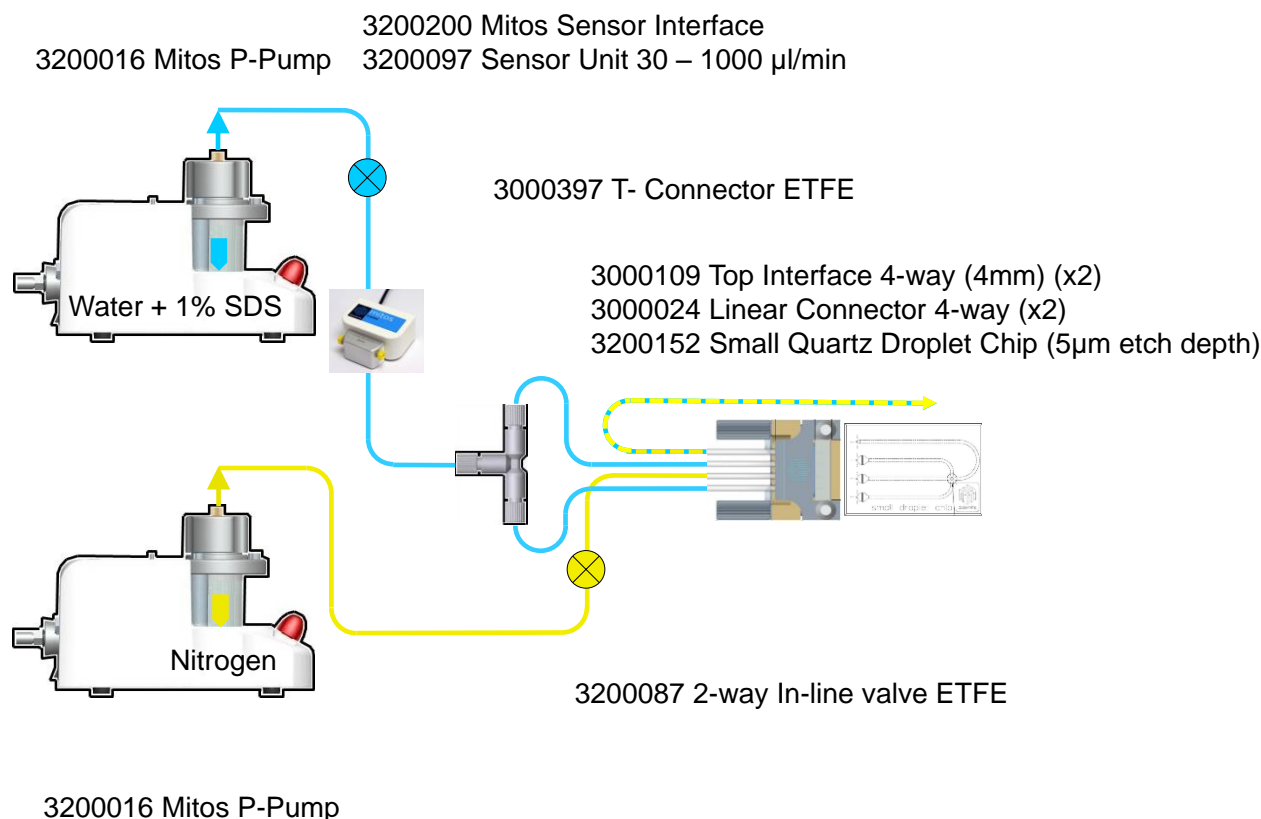

Schematic showing assembly of standard components. Complete parts list can be found in the Appendix.

FEP tubing (Part No. 3200063) (1/16" x 0.25mm, 10 metres) and PEEK tubing (OD 1/16", ID 25 µm, L 1500 mm) (Part No. 3200417) are used to deliver fluids across the system. Suitable lengths of tubing are cut as flow resistors and connected in the setup as shown in the block diagram below. The T-Connector ETFE (Part No. 3000397) has 0.5mm I.D. for 1.6mm (1/16") O.D. Pipe, and splits the single FEP tube with the carrier water into two separate FEP tubes leading to the Linear Connector 4-way. The 2-way In-line Valve (Part No. 3200087) is an ETFE shut-off valve 0.5 mm I.D. with fittings for 1.6 mm (1/16") O.D. tubing, and is used for the PEEK tubing carrying the droplet phase nitrogen to the Linear Connector 4-way. The collection point for the fluid after it passes through the Small Quartz Droplet Chip and Top Interface 4-way is a microcentrifuge tube.

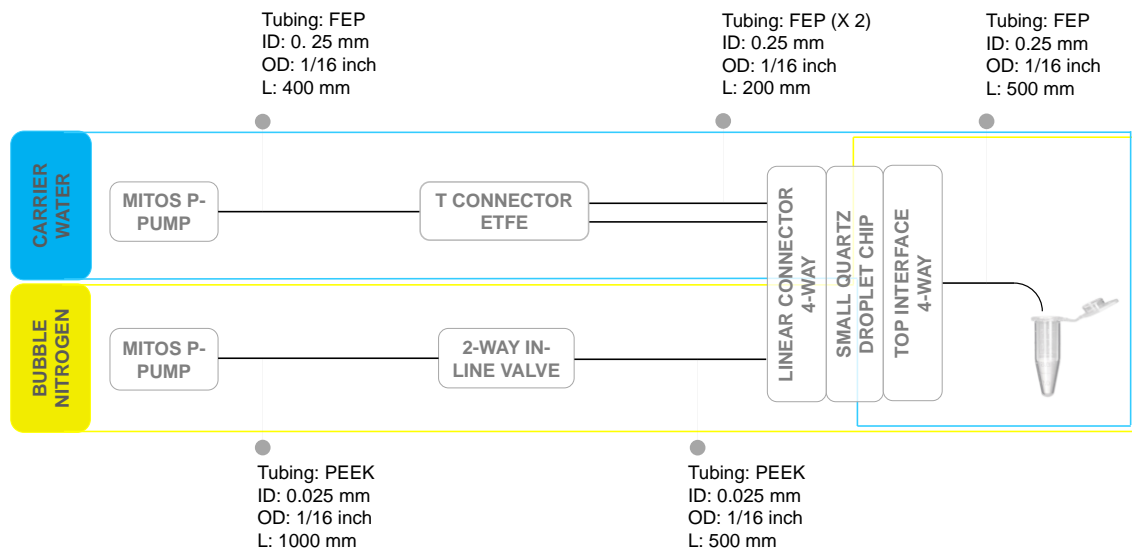

Tubing details used in the connections used for the bubble generation setup

A High Speed Camera and Microscope System (Part No. 3200050) was used for visualization of the Small Quartz Droplet Chip.

Test Results

The figure alongside shows the flow rates of the carrier water. This includes effects due to the variability when the gas pressure is changed. Still, the spread is found to be narrow. The 'x'-intercept of the trend-line suggests an equilibrium junction pressure of approximately 3 bar. Below this pressure, backflow occurs, where the water flows backwards. This is undesirable. Alternatively, raising the gas pressure too high results in coalescence and chaotic flow patterns. The gas being of much lower viscosity is unlikely to undergo backflow. The PEEK tubing with ID 25 μm has been used in this case to minimize backflow. If larger ID tubing is used, then the possibility of backflow is higher. Smaller ID tubing is preferable, but at risk of blockage from dust particles (dust particles are $\sim 20 \mu\text{m}$ in size).

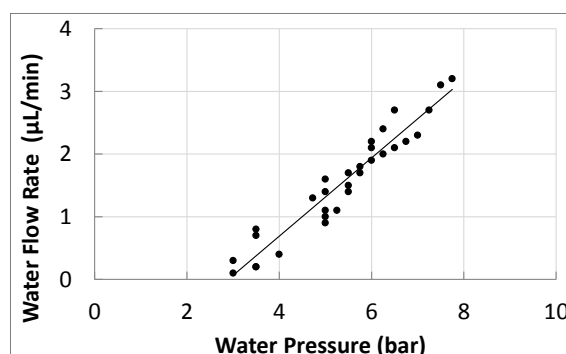

Range of carrier flow rates achieved during test. The spread in the data represents the variation due to gas pressures in the range of 3 to 5 bar.



As the relative pressures are changed, the relative flows change, consequently yielding larger or smaller bubbles. The relation between the bubble size and the amount of gas contained within is presented in the table below. It should be noted that the size of the bubble will change as it flows downstream of the pressure gradient. A $PV = nRT$ relationship is useful for ideal gas to estimate the quantity of gas contained within.

Bubble Diameter (micrometers)	Bubble Volume (picoliters)
5	0.065
10	0.524
15	1.767
20	4.189

Size to volume conversion

The high speed camera integrates with the microscope and provides image capture at speeds of over 1000fps via FireWire link to a desktop PC to interface with a computer based image capture system. Pixel analysis of images enables estimation of bubble size. The absolute size of the 8 μm wide channel opening provides the benchmark to estimate the bubble size. Some representative images of bubble generation are shown in the below table along with flow conditions.

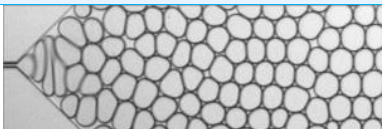
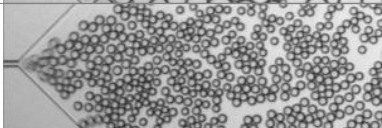
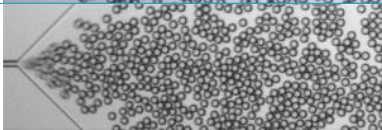
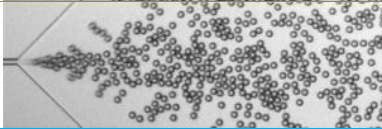
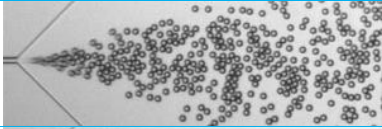
The N_2 gas flow rate is estimated to be less than 1 $\mu\text{L}/\text{min}$. The flow rate of water varies between 0.1 to 5 $\mu\text{L}/\text{min}$. There are limits to the size of stable bubbles with a strong dependence on the channel depth. The depth in the current chip is 5 μm , and therefore bubbles that appear larger than the depth are flattened. Care should be taken therefore in estimating the sizes, as the size will change when the bubbles leave the chip.

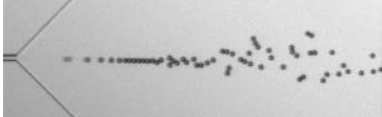
Nitrogen	Water	Water	Junction Image	Bubble Diameter
P	P	Q		ϕ
[bar]	[bar]	[$\mu\text{L}/\text{min}$]		[μm]
3.25	3	0.1		40
5	5	0.9		15
5	5.25	1.1		11
5	5.5	1.5		9
5	5.75	1.8		8
5	6	2.1		7
5	6.25	2.4		6

Bright field direct microscopy images obtained from the ROI, showing N₂ bubbles in Water. Flow direction is from left to right. The bubbles are produced at the flow focussing junction immediately to the left, and just outside the left boundary of the images.

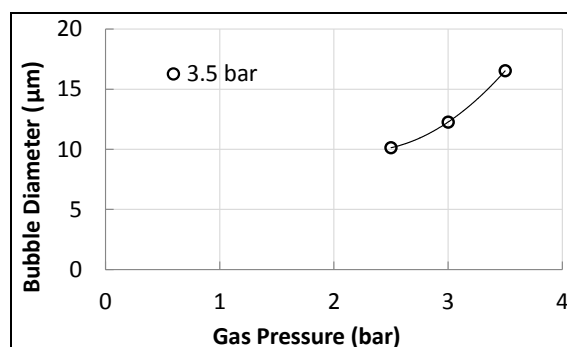
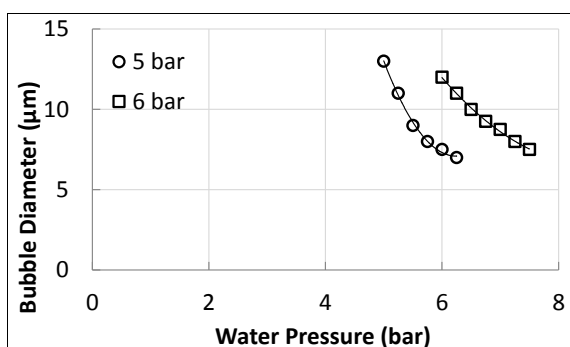

Left: Dependence of bubble size on water pressures for gas pressure of 5 bar, and 6 bar respectively. Right: Dependence of bubble size on gas pressure at water pressure of 3.5 bar.

Shown above are graphics depicting the variation of bubble size with changes in pressure ratio. As the gas pressure is held at 5 bar, increasing the carrier water pressure causes a reduction in the bubble size – reduction from 13 μm to 6 μm . Above and below this size, unstable bubble is produced. Similarly, when the gas pressure is held at 6 bar, the size variation is from 12 μm to 7 μm . In another study, the gas pressure was increased from 2.5 bar to 3.5 bar while the water carrier pressure was held at 3.5 bar.

The pressures ratio ($P_{\text{gas}}/P_{\text{carrier}}$), dictates the stability of the bubbles and is controlled with P-Pumps. At extreme ratios, very large bubbles are produced, or backflow occurs. Large bubbles are likely to coalesce in the absence of a stabilizing surfactant. By controlling the pressure ratio, a wide range of bubble sizes can be generated.

Bubble generation is dependent on the pressure balance at the junction. In the images above, the gas pressure is held constant, and the carrier pressure is varied. It can be seen that as the carrier pressure increases, this changes the pressure ratio at the junction, and the flow of the carrier water increases. This results in a lower flow rate for the gas, thereby resulting in smaller and slower bubbles. On the contrary, if the carrier water pressure were held constant and the gas pressure increased, the outcome would be larger and faster bubbles.

Rough estimates of bubble frequencies are between 10 to 1000 bubbles per second. In general, higher total flows generate higher bubble generation rates. Increasing the Nitrogen pressure (or reducing the water pressure) results in larger bubbles. Reducing Nitrogen pressure (or increasing water pressure) produces smaller bubbles.



Conclusion

The successful rapid (10-1000 Hz) monodisperse generation of gas bubbles in the 6-40 μm diameter size range has been demonstrated with the Small Quartz Droplet Chip. Current production methods of micro bubbles result in distributions with a large size variance, yet a high degree of stability can be maintained with the P-Pump. Gas bubble generation is dependent on the pressure balance at the junction of the Small Quartz Droplet Chip, and various possibilities arise simply by controlling P-Pump pressures. As relative pressures change, relative flow changes, yielding larger or smaller bubbles, with the size of the 8 μm wide channel opening of the Small Quartz Droplet Chip providing the benchmark for estimating bubble size.

The wide range of gas bubble size and generation frequency, as well as the consistent characteristics of the gas bubbles generated in this application note means that the Small Quartz Droplet Chip could potentially lend itself to applications such as foam generation, polydisperse bubbles, single file bubbles and merging bubbles. The low limit of bubble diameter achieved (6 μm) demonstrates the potential of the Small Quartz Droplet Chip to be used in highly specialised applications in large markets as mentioned previously in this application note, where fine monodisperse bubbles (and therefore increased surface area) and control of the bubble size is required in processes and in actual products.

Dolomite offers the complete microfluidic solution – the Small Quartz Droplet Chip can be used with existing Dolomite pumps, connectors, interfaces, valves, tubing and camera and microscope systems. This means small size and batch manufacturability and a versatile platform for fast performing measurements analysis.

IP License

Dolomite is a licensee of Japan Science and Technology Agency (“JST”) under JST’s microdroplet generation technology.

This enables our customers to purchase and use our droplet chips for R&D purposes without any restriction from this comprehensive IP family.

Contact us for more information about licensing this IP for your custom application or chip design.

Appendix A: System Component List

Part No.	Part Description	#
3200152	Small Quartz Droplet Chip (5µm etch depth)	1
3000024	Linear Connector 4-way	1
3000109	Top Interface 4-way (4mm)	1
3200016	Mitos P-Pump	2
3200063	FEP Tubing, 1/16" x 0.25mm, 10 metres	1
3200417	PEEK tubing (OD 1/16", ID 25 µm, L 1500 mm)	1
3200087	2-way In-line Valve	2
3000397	T-Connector ETFE	1
3200050	High Speed Camera and Microscope System	1
3200244	Mitos Flow Rate Sensor, mixed pack of 3	1
3200245	Ferrule with Integrated Filter (pack of 10)	1

Appendix B : Alternative Chip Options

Part No.	Part Description	#
3200136	Small Droplet Chip (14µm etch depth)	1
3000146	Small Quartz Droplet Chip (14µm etch depth)	1

Glass and Quartz chips work equally well in bubble generation applications. A 14µm etch depth offers the opportunity to produce bubbles in the 10-25µm size range, as opposed to the 6-15µm range achieved with the Small Quartz Droplet Chip (5µm etch depth) (Part No. 3200152) used in this application note.



The Dolomite Centre Ltd.

Unit 1, Anglian Business Park, Royston,
Hertfordshire, SG8 5TW, United Kingdom

T: +44 (0)1763 242491

F: +44 (0)1763 246125

E: info@dolomite-microfluidics.com

W: www.dolomite-microfluidics.com

Dolomite Microfluidics

29 Albion Place
Charlestown, MA 02129

F: 617 848 1211

F: 617 500 0136

E: salesus@dolomite-microfluidics.com

W: www.dolomite-microfluidics.com